

# METAL FITTINGS FOR STRIP CURTAIN

Different sheet fittings can be chosen according to site requirements.

## MC series · ZS series

Common structure for installation, with variety of overlap rates and it can use different fittings according to opening dimensions.

### A-MC Fixing type

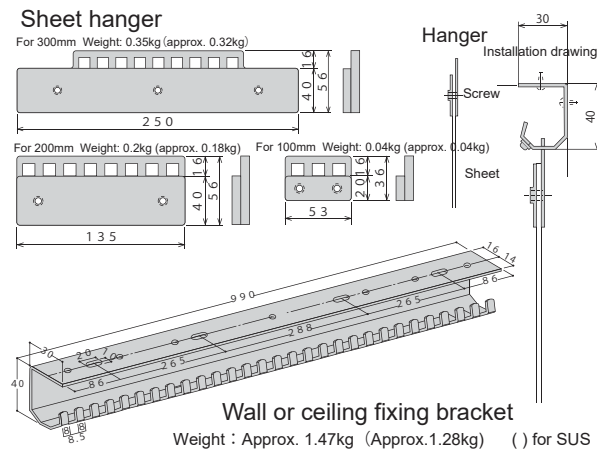

## SW series

With the sheet hanger and bracket in strong durability. Suitable for such sites where there are many traffic of carts as plants or warehouses.

### A-SW Fixing type for sheet width 200mm and 300mm

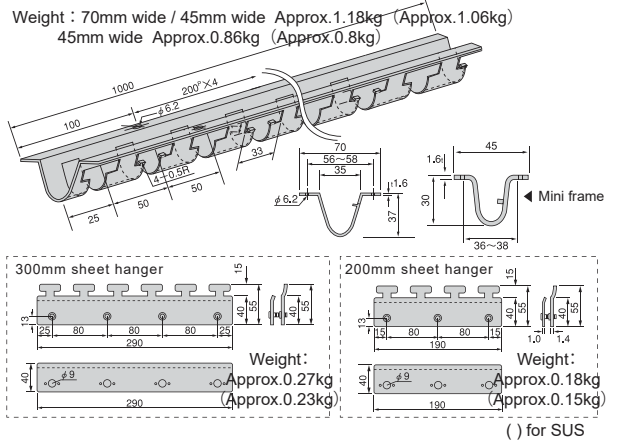

### B-ZS Sliding type

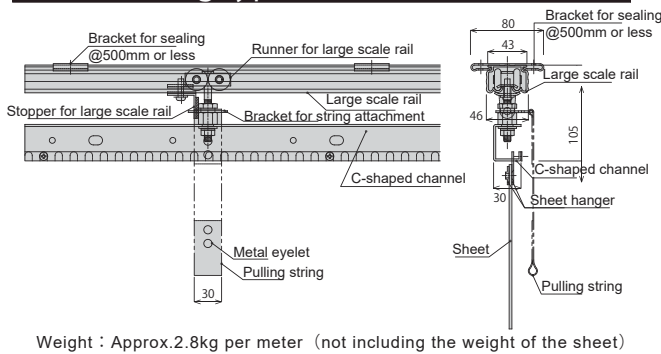

### B-SW Sliding type for sheet width 200mm and 300mm

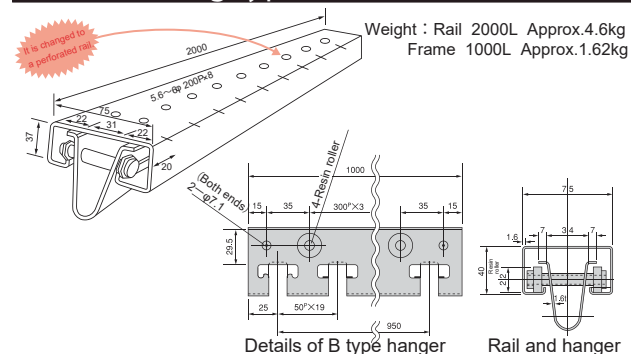

### C-ZS Accordion type

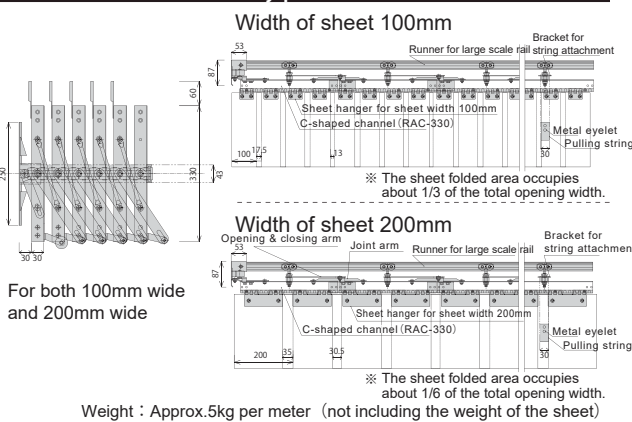

### C-SW Accordion type for sheet width 300mm

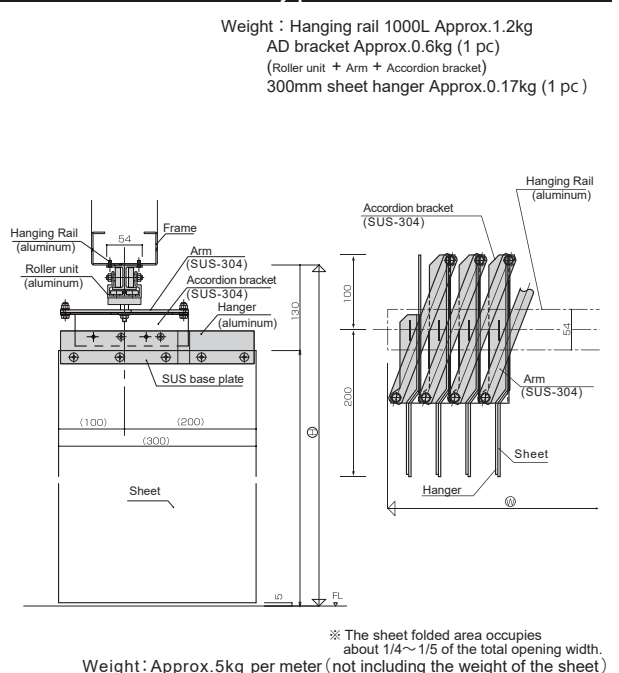

### Width of sheet 300mm

