

Section shown by slant lines indicates position to install the seal gasket.
Core of door: • lumber core
Opening frame for door installation (3-sided-frame) and back plate for reinforcement should be prepared by customer.

Code	How many	Where to install
-	-	~
Type	SWING DOOR SCG-3V (double door)	

No.	Name	Material	Remark
1	Surface material	Stainless steel	thickness 0.8 mm
2	Seal gasket	PVC	-
3	Window	Acrylic resin	color: transparent/thickness 4.0 mm
4	Window frame	Aluminum	color: alumite silver
5	Screw	Stainless steel	+A truss tapping/5x18
6	V-hinge	Polyacetal	color: grey
7	Screw	Stainless steel	+ Bind screw M8x15
8	Opening frame for door installation (3-sided-frame)	-	Prepared by customers

Possible dimensions for production

	Single door	Double door
Opening width (W)	$610 \leq W \leq 915$	$1215 \leq W \leq 2400$
Opening height (H)	$1000 \leq H \leq 2400$	

Window size

Door width (DW)	Window width	Window height
$620 \leq DW$	355	420
$400 \leq DW < 620$	200	420
$DW < 400$	No window	

*Window sizes other than the above can be used depending on the height (H) and position of the window (to be confirmed)
* Minimum opening for window: w200 h250
* Vertical position of window: requires minimum 500 from door panel bottom edge and minimum 200 from door panel upper edge.

Qty of v-hinge installed

	Opening width (W)	Qty (per one door panel)
Single door	$610 \leq W \leq 1015$	2
	$1016 < W \leq 1200$	3
Double door	$1215 \leq W \leq 2030$	2
	$2031 < W \leq 2400$	3

Drawing name
UNIFLOW SWING DOOR
SCG-3V (double door)
Image of basic installation

株式会社ユニフロー

Scale
1/20
Drawing No. -
Date - . - . -

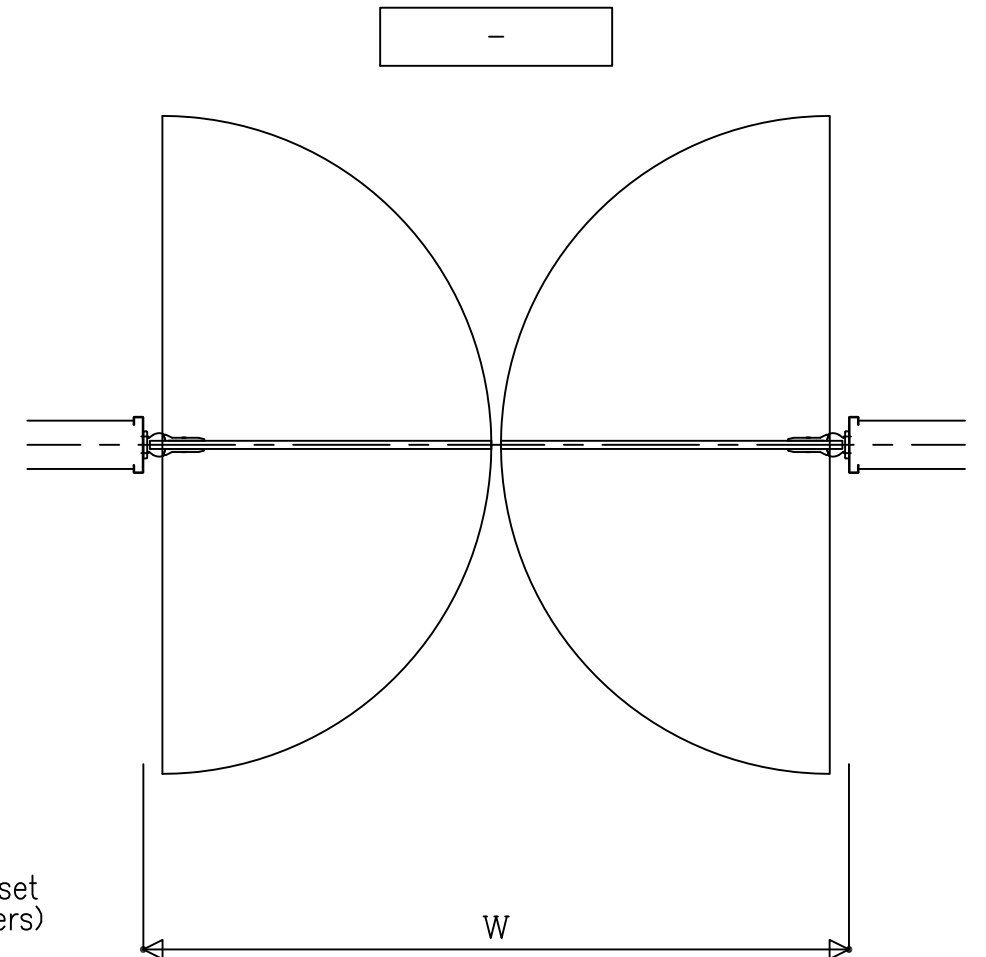
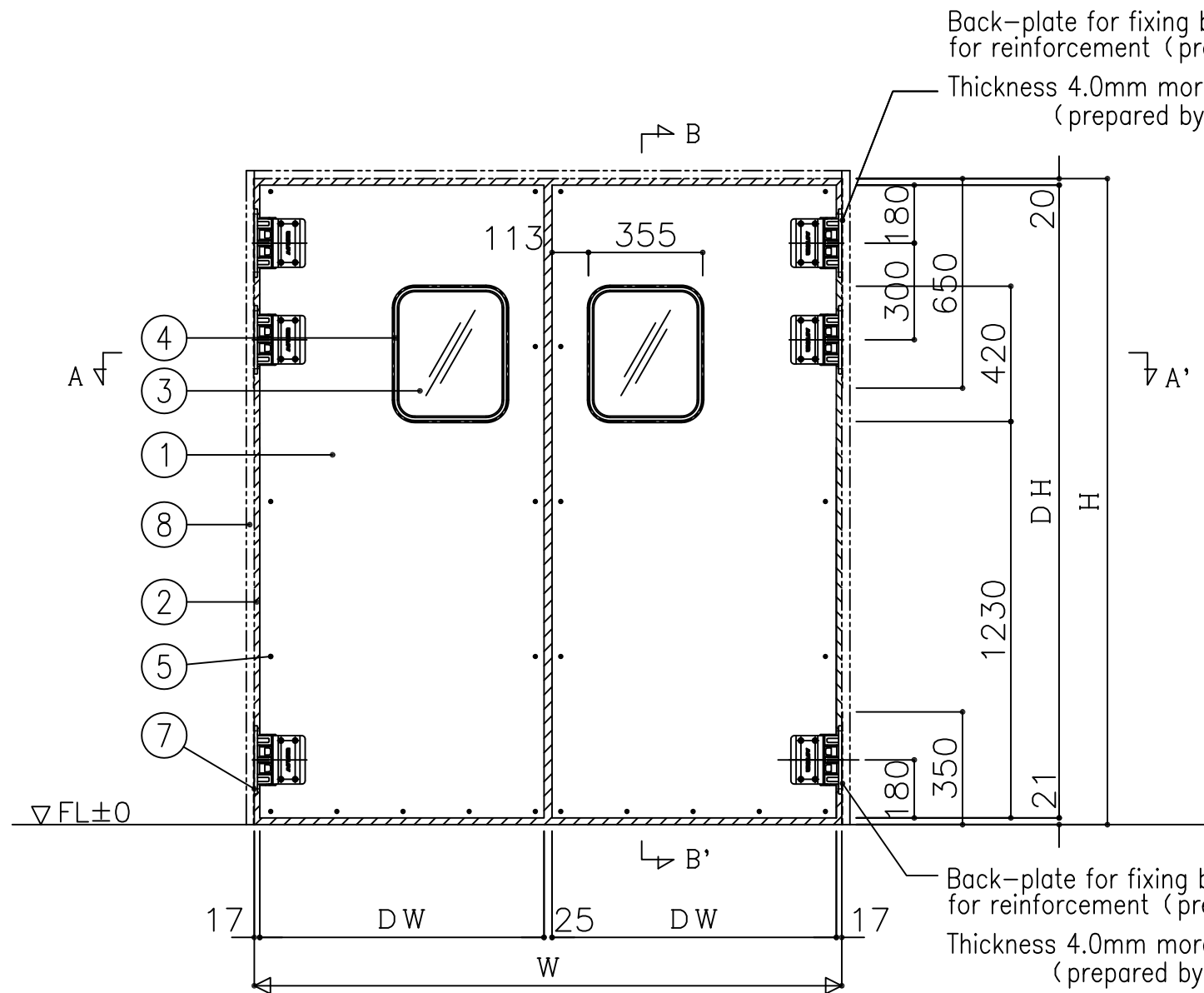

Section shown by slant lines indicates position to install the seal gasket.
 Core of door • lumber core
 Opening frame for door installation (3-sided-frame) and back plate for reinforcement should be prepared by customer.

Possible dimensions for production

	Single door	Double door
Opening width (W)	610 ≤ W ≤ 915	1215 ≤ W ≤ 2400
Opening height (H)	1000 ≤ H ≤ 2400	

Window size

Door width (DW)	Window width	Window height
620 ≤ DW	355	420
400 ≤ DW < 620	200	420
DW < 400	No window	

*Window sizes other than the above can be used depending on the height (H) and position of the window (to be confirmed)
 * Minimum opening for window: w200 h250
 * Vertical position of window: requires minimum 500 from door panel bottom edge and minimum 200 from door panel upper edge.

Code	How many	Where to install
—	—	~
Type	SWING DOOR SCG-3V (double door)	

Qty of v-hinge installed

	Opening width (W)	Qty (per one door panel)
Single door	610 ≤ W ≤ 1015	2
	1016 < W ≤ 1200	3
Double door	1215 ≤ W ≤ 2030	2
	2031 < W ≤ 2400	3

No.	Name	Material	Remark
1	Surface material	Stainless steel	thickness 0.8 mm
2	Seal gasket	PVC	—
3	Window	Acrylic resin	color: transparent/thickness 4.0 mm
4	Window frame	Aluminum	color: alumite silver
5	Screw	Stainless steel	+A truss tapping/5x18
6	V-hinge	Polyacetal	color: grey
7	Screw	Stainless steel	+ Bind screw M8x15
8	Opening frame for door installation (3-sided-frame)	—	Prepared by customers

Drawing name
 UNIFLOW SWING DOOR
 SCG-3V (double door)
 Image of basic installation



Scale

1/20

Drawing No. —

Date — · — · —

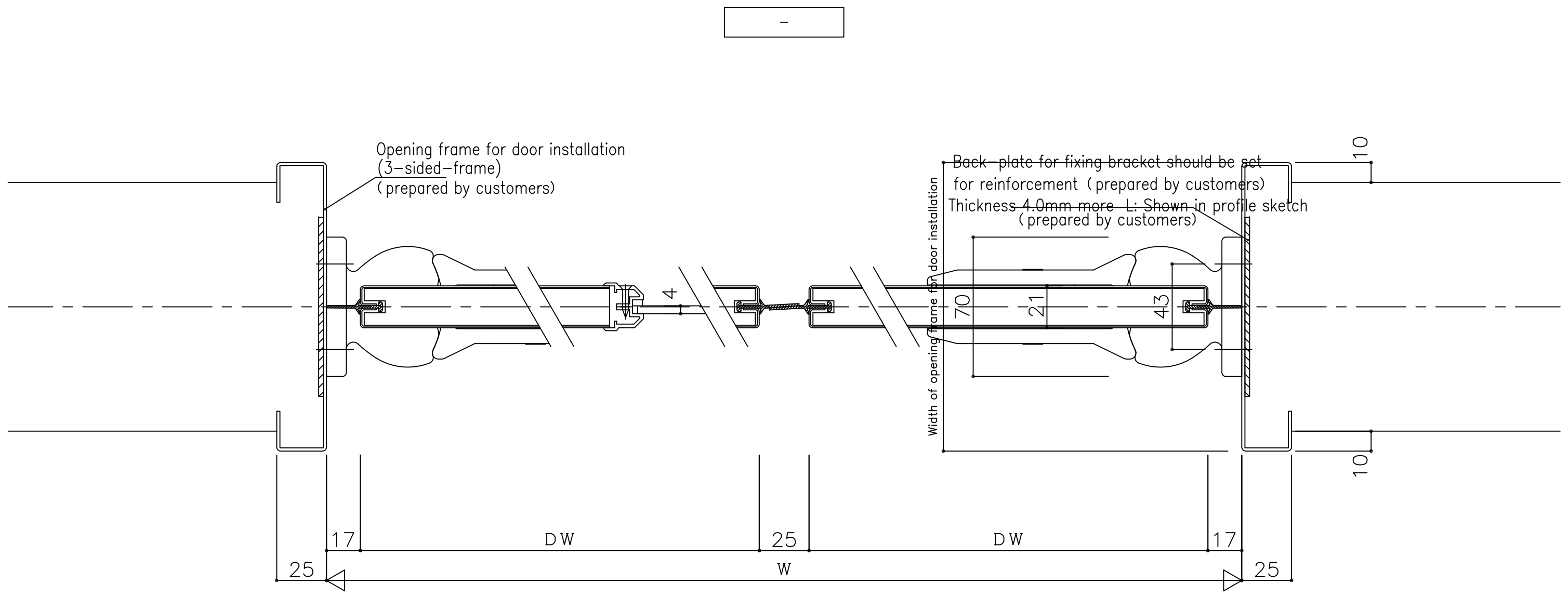

A-A' section

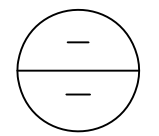

- - - - -				Drawing name UNIFLOW SWING DOOR SCG-3V (double door) cross section				Scale 1/2 /	Drawing No. - Date - - - - -
-----------	--	--	--	---	--	--	--	-------------------	---------------------------------

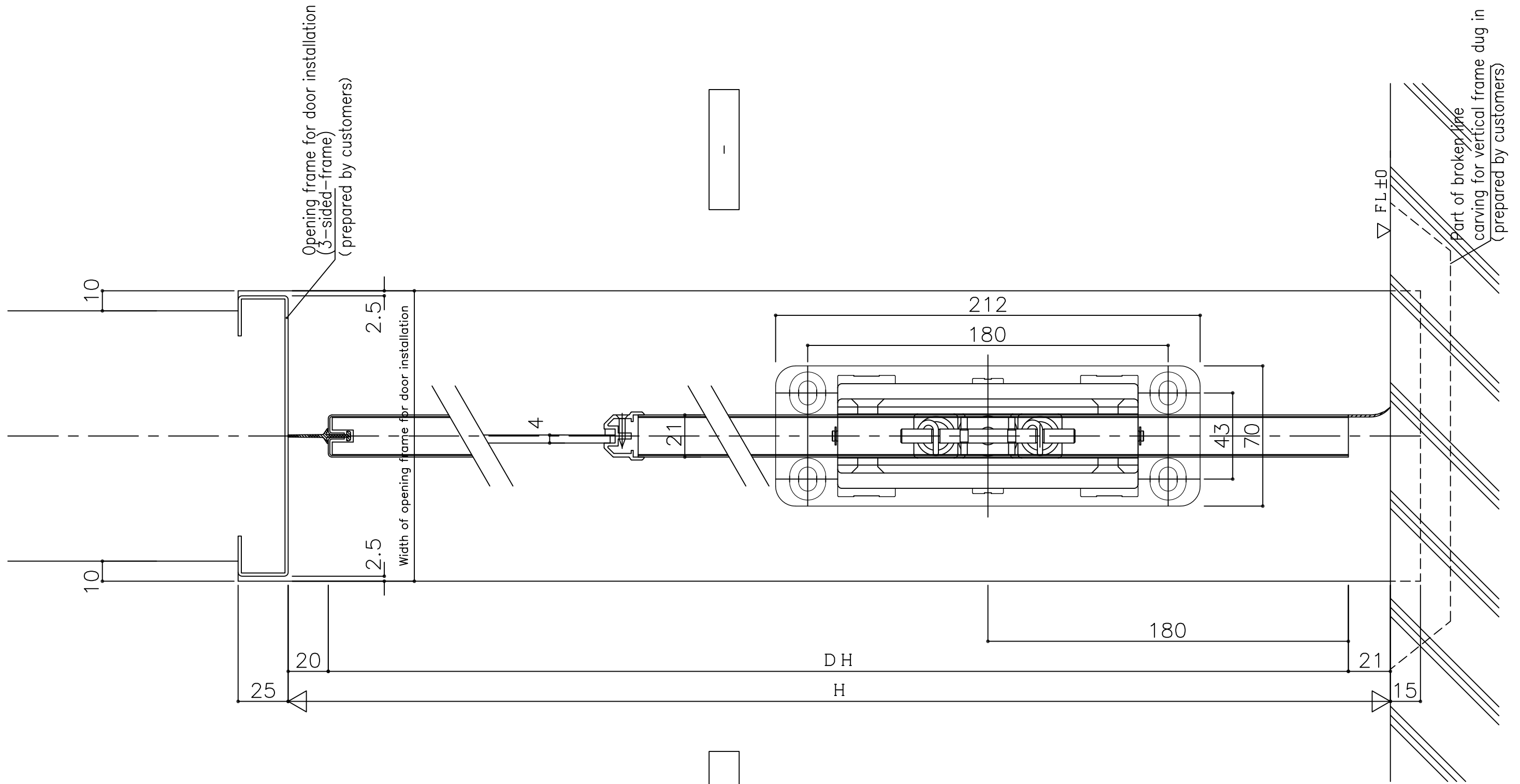

B-B' section

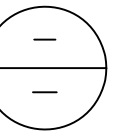

-	○	○	○	-
○	○	○	○	-
○	○	○	○	-
○	○	○	○	-
○	○	○	○	-

Drawing name
 UNIFLOW SWING DOOR
 SCG-3V (double door)
 vertical section



Scale
 1/2

Drawing No. -
 Date - - - - -

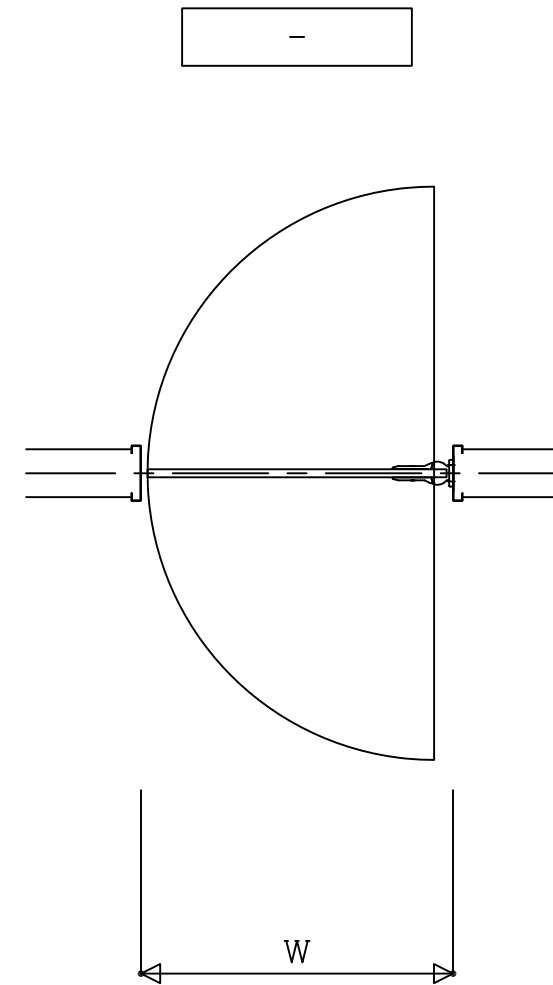
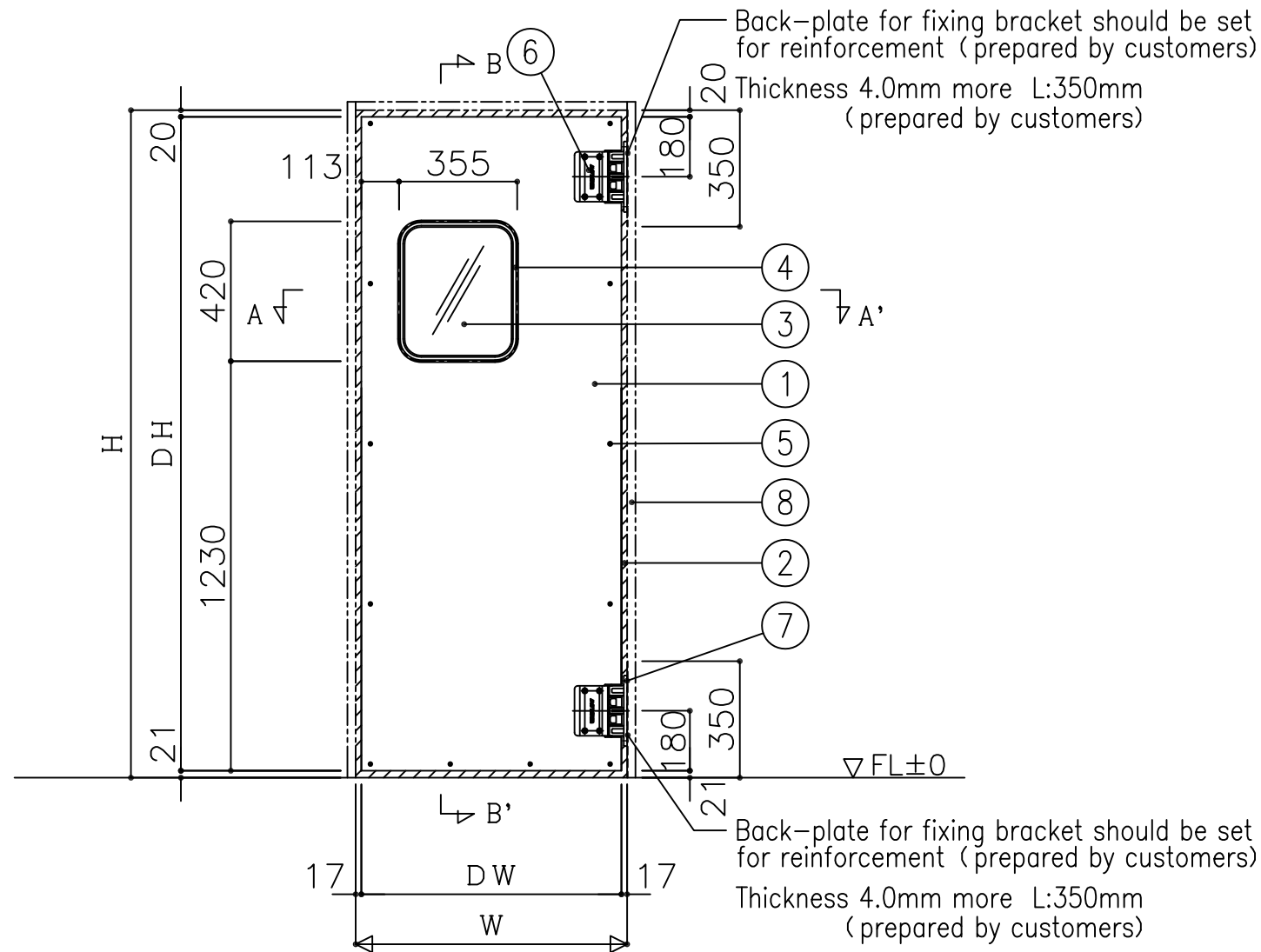

 Section shown by slant lines indicates position to install the seal gasket.
 Core of door: • lumber core
 Opening frame for door installation (3-sided-frame) and back plate for reinforcement should be prepared by customer.

Possible dimensions for production

	Single door	Double door
Opening width (W)	$610 \leq W \leq 915$	$1215 \leq W \leq 2400$
Opening height (H)	$1000 \leq H \leq 2400$	

Window size

Door width (DW)	Window width	Window height
$620 \leq DW$	355	420
$400 \leq DW < 620$	200	420
$DW < 400$	No window	

*Window sizes other than the above can be used depending on the height (H) and position of the window (to be confirmed)
 * Minimum opening for window: w200 h250
 * Vertical position of window: requires minimum 500 from door panel bottom edge and minimum 200 from door panel upper edge.

Code	How many	Where to install
①	-	~
Type	SWING DOOR SCG-3V (single door)	

Qty of v-hinge installed

	Opening width (W)	Qty (per one door panel)
Single door	$610 \leq W \leq 1015$	2
	$1016 < W \leq 1200$	3
Double door	$1215 \leq W \leq 2030$	2
	$2031 < W \leq 2400$	3

No.	Name	Material	Remark
1	Surface material	Stainless steel	thickness 0.8 mm
2	Seal gasket	PVC	-
3	Window	Acrylic resin	color: transparent/thickness 4.0 mm
4	Window frame	Aluminum	color: alumite silver
5	Screw	Stainless steel	+A truss tapping/5x18
6	V-hinge	Polyacetal	color: grey
7	Screw	Stainless steel	+ Bind screw M8x15
8	Opening frame for door installation (3-sided-frame)	-	Prepared by customers

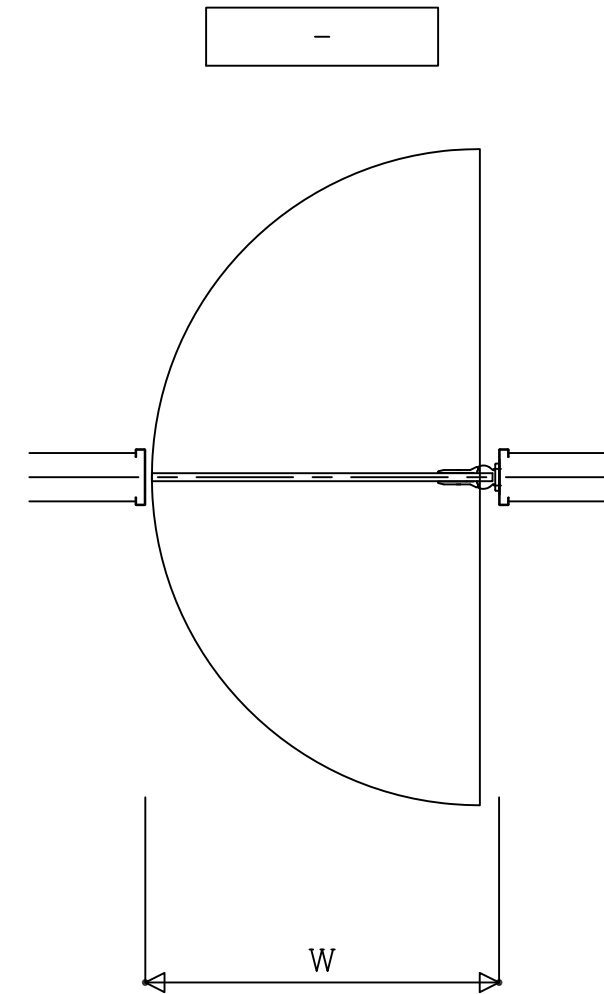
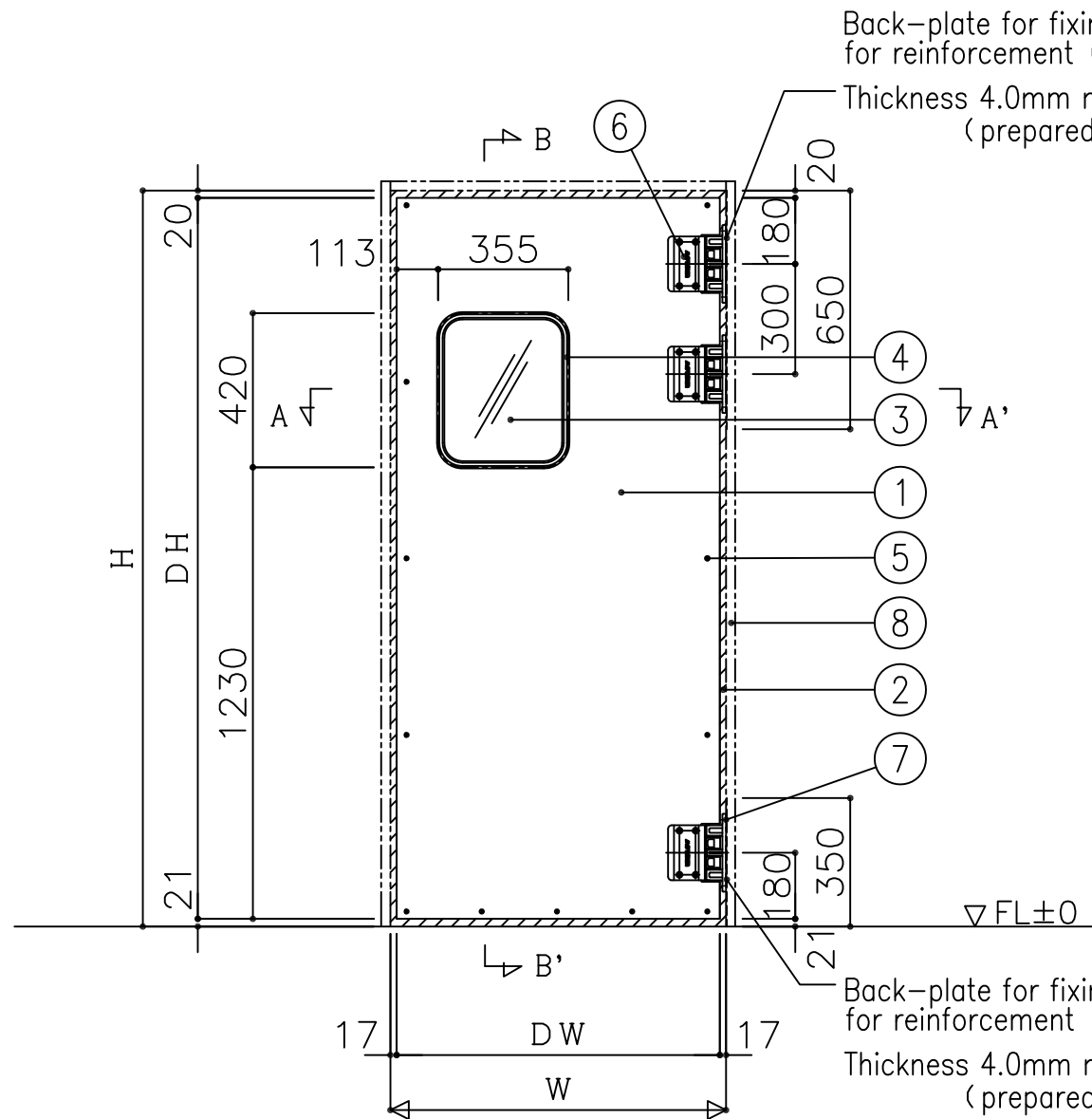

Section shown by slant lines indicates position to install the seal gasket.
 Core of door • • lumber core
 Opening frame for door installation (3-sided-frame) and back plate for reinforcement should be prepared by customer.

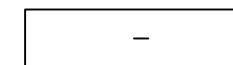

Code	How many	Where to install
⊖	-	~
Type	SWING DOOR SCG-3V (double door)	

No.	Name	Material	Remark
1	Surface material	Stainless steel	thickness 0.8 mm
2	Seal gasket	PVC	-
3	Window	Acrylic resin	color: transparent/thickness 4.0 mm
4	Window frame	Aluminum	color: alumite silver
5	Screw	Stainless steel	+A truss tapping/5x18
6	V-hinge	Polyacetal	color: grey
7	Screw	Stainless steel	+ Bind screw M8X15
8	Opening frame for door installation (3-sided-frame)	-	Prepared by customers

Possible dimensions for production

	Single door	Double door
Opening width (W)	610 ≤ W ≤ 915	1215 ≤ W ≤ 2400
Opening height (H)	1000 ≤ H ≤ 2400	

Window size

Door width (DW)	Window width	Window height
620 ≤ DW	355	420
400 ≤ DW < 620	200	420
DW < 400	No window	

*Window sizes other than the above can be used depending on the height (H) and position of the window (to be confirmed)
 * Minimum opening for window: w200 h250
 * Vertical position of window: requires minimum 500 from door panel bottom edge and minimum 200 from door panel upper edge.

Qty of v-hinge installed

	Opening width (W)	Qty (per one door panel)
Single door	610 ≤ W ≤ 1015	2
	1016 < W ≤ 1200	3
Double door	1215 ≤ W ≤ 2030	2
	2031 < W ≤ 2400	3

Drawing name
 UNIFLOW SWING DOOR
 SCG-3V (single door)
 Image of basic installation



Scale
 1/20
 Drawing No. -
 Date - . - . -

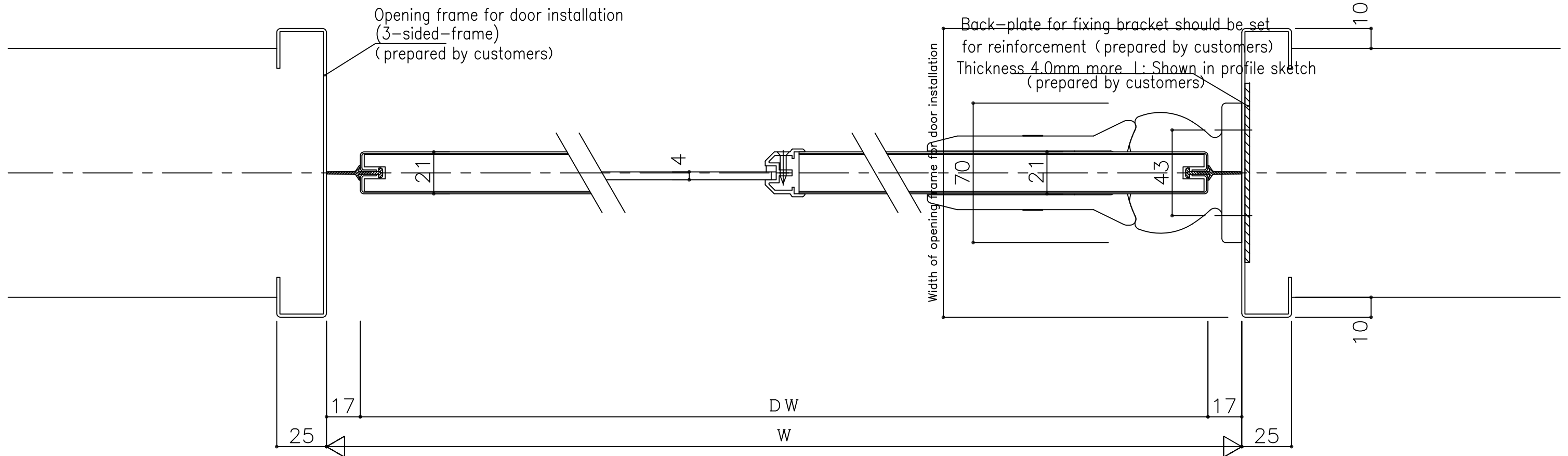

A-A' section

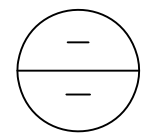

<table border="1"> <tr><td>-</td><td>o</td><td>o</td><td>o</td><td>-</td></tr> <tr><td>o</td><td>o</td><td></td><td></td><td></td></tr> <tr><td>o</td><td>o</td><td></td><td></td><td></td></tr> <tr><td>o</td><td>o</td><td></td><td></td><td></td></tr> <tr><td>o</td><td>o</td><td></td><td></td><td></td></tr> </table>	-	o	o	o	-	o	o				o	o				o	o				o	o						Drawing name UNIFLOW SWING DOOR SCG-3V (single door) cross section					Scale 1/2 /	Drawing No. - Date - o - o -
-	o	o	o	-																														
o	o																																	
o	o																																	
o	o																																	
o	o																																	

Back-plate for fixing bracket should be set for reinforcement (prepared by customers)
Thickness 4.0mm more L:350mm (prepared by customers)

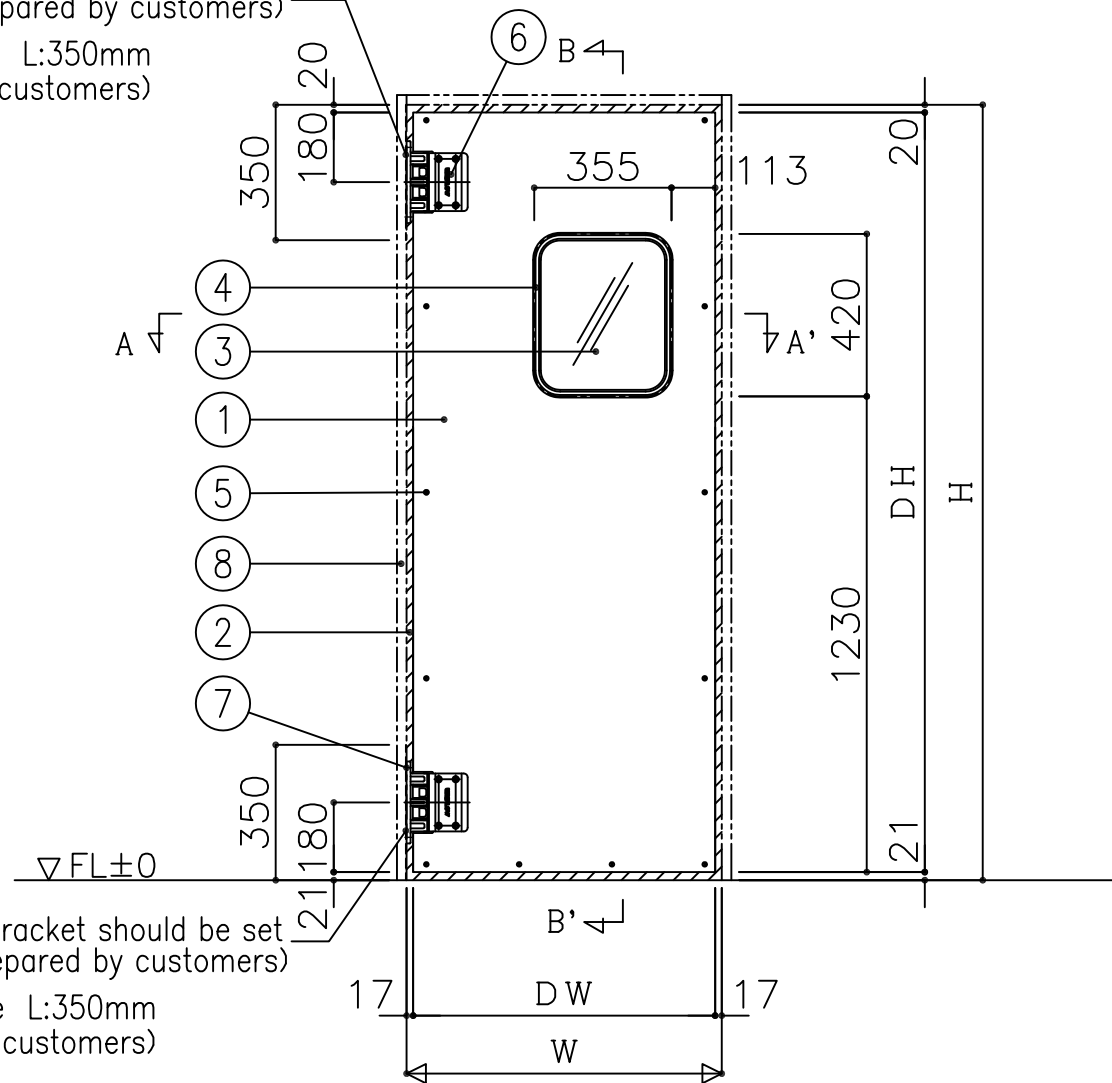

Back-plate for fixing bracket should be set for reinforcement (prepared by customers)
Thickness 4.0mm more L:350mm (prepared by customers)

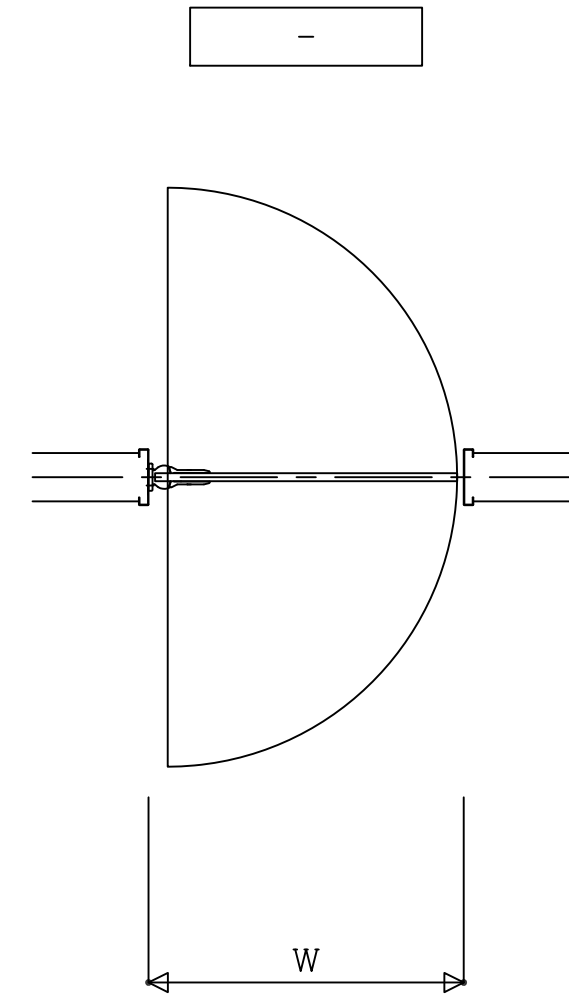

Section shown by slant lines indicates position to install the seal gasket.
Core of door • • lumber core
Opening frame for door installation (3-sided-frame) and back plate for reinforcement should be prepared by customer.

Code	How many	Where to install
⊖	-	~
Type	SWING DOOR SCG-3V (double door)	

Possible dimensions for production

	Single door	Double door
Opening width (W)	610 ≤ W ≤ 915	1215 ≤ W ≤ 2400
Opening height (H)	1000 ≤ H ≤ 2400	

No.	Name	Material	Remark
1	Surface material	Stainless steel	thickness 0.8 mm
2	Seal gasket	PVC	-
3	Window	Acrylic resin	color: transparent/thickness 4.0 mm
4	Window frame	Aluminum	color: alumite silver
5	Screw	Stainless steel	+A truss tapping/5x18
6	V-hinge	Polyacetal	color: grey
7	Screw	Stainless steel	+ Bind screw M8X15
8	Opening frame for door installation (3-sided-frame)	-	Prepared by customers

Door width (DW)	Window size	
	Window width	Window height
620 ≤ DW	355	420
400 ≤ DW < 620	200	420
DW < 400	No window	

*Window sizes other than the above can be used depending on the height (H) and position of the window (to be confirmed)
* Minimum opening for window: w200 h250
* Vertical position of window: requires minimum 500 from door panel bottom edge and minimum 200 from door panel upper edge.

	Qty of v-hinge installed	
	Opening width (W)	Qty (per one door panel)
Single door	610 ≤ W ≤ 1015	2
	1016 < W ≤ 1200	3
Double door	1215 ≤ W ≤ 2030	2
	2031 < W ≤ 2400	3

Drawing name
UNIFLOW SWING DOOR
SCG-3V (single door)
Image of basic installation

UNIFLOW

Scale 1/20
Drawing No. -
Date - . - . -

Back-plate for fixing bracket should be set for reinforcement (prepared by customers)
Thickness 4.0mm more L:650mm (prepared by customers)

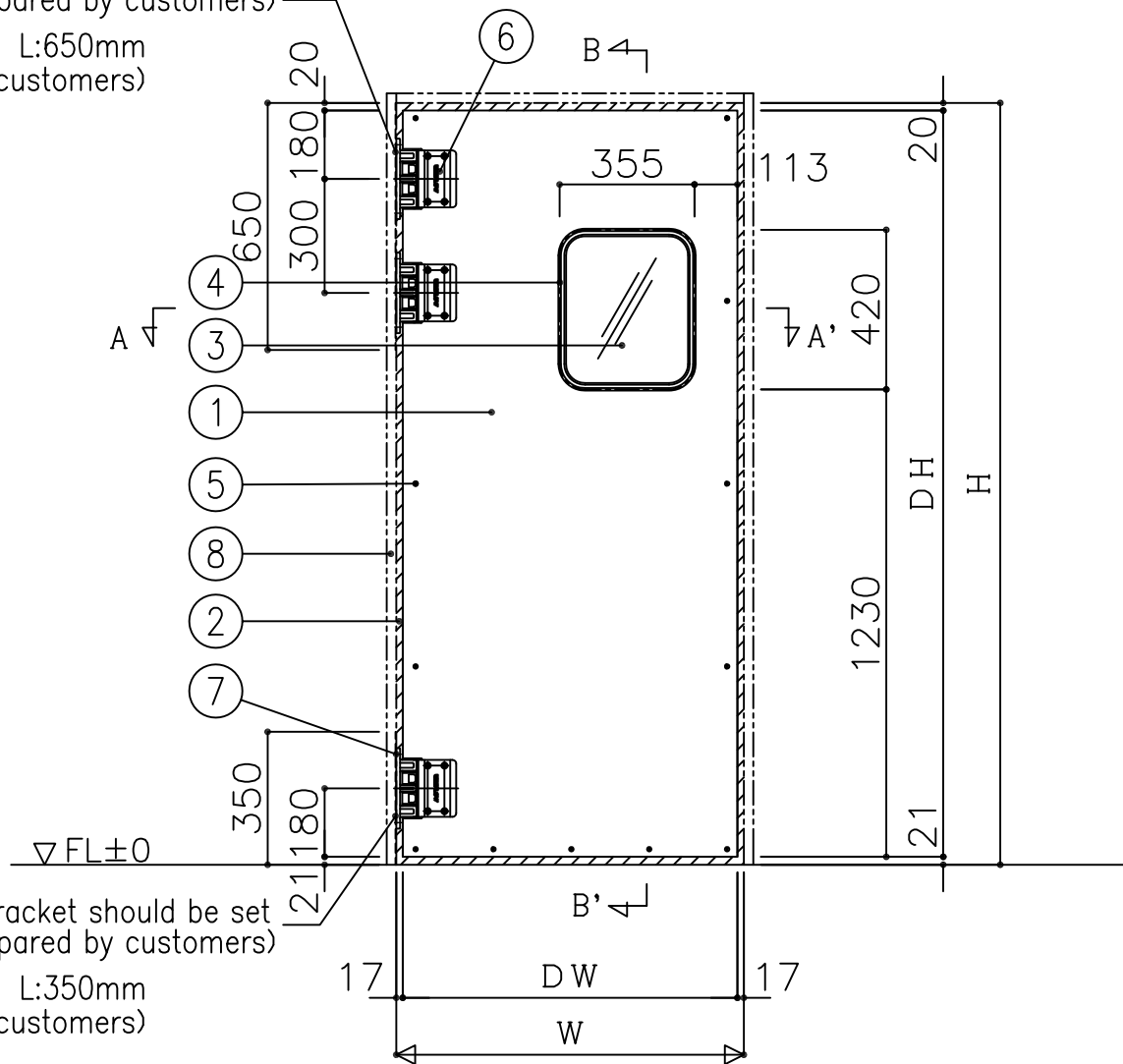

Back-plate for fixing bracket should be set for reinforcement (prepared by customers)
Thickness 4.0mm more L:350mm (prepared by customers)

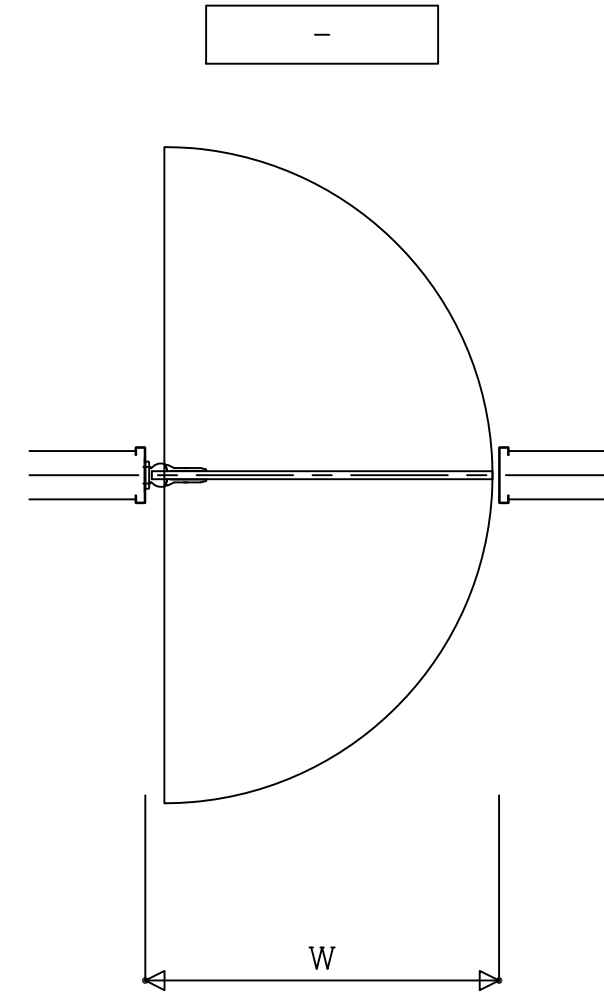

Section shown by slant lines indicates position to install the seal gasket.
Core of door • lumber core
Opening frame for door installation (3-sided-frame) and back plate for reinforcement should be prepared by customer.

Code	How many	Where to install
—	—	~
Type	SWING DOOR SCG-3V (double door)	

No.	Name	Material	Remark
1	Surface material	Stainless steel	thickness 0.8 mm
2	Seal gasket	PVC	-
3	Window	Acrylic resin	color: transparent/thickness 4.0 mm
4	Window frame	Aluminum	color: alumite silver
5	Screw	Stainless steel	+A truss tapping/5x18
6	V-hinge	Polyacetal	color: grey
7	Screw	Stainless steel	+ Bind screw M8x15
8	Opening frame for door installation (3-sided-frame)	-	Prepared by customers

Possible dimensions for production

	Single door	Double door
Opening width (W)	$610 \leq W \leq 915$	$1215 \leq W \leq 2400$
Opening height (H)	$1000 \leq H \leq 2400$	

Window size

Door width (DW)	Window width	Window height
$620 \leq DW$	355	420
$400 \leq DW < 620$	200	420
$DW < 400$	No window	

*Window sizes other than the above can be used depending on the height (H) and position of the window (to be confirmed)
* Minimum opening for window: w200 h250
* Vertical position of window: requires minimum 500 from door panel bottom edge and minimum 200 from door panel upper edge.

Qty of v-hinge installed

	Opening width (W)	Qty (per one door panel)
Single door	$610 \leq W \leq 1015$	2
	$1016 < W \leq 1200$	3
Double door	$1215 \leq W \leq 2030$	2
	$2031 < W \leq 2400$	3

Drawing name
UNIFLOW SWING DOOR
SCG-3V (single door)
Image of basic installation

UNIFLOW

Scale
1/20
Drawing No. -
Date - . - . -

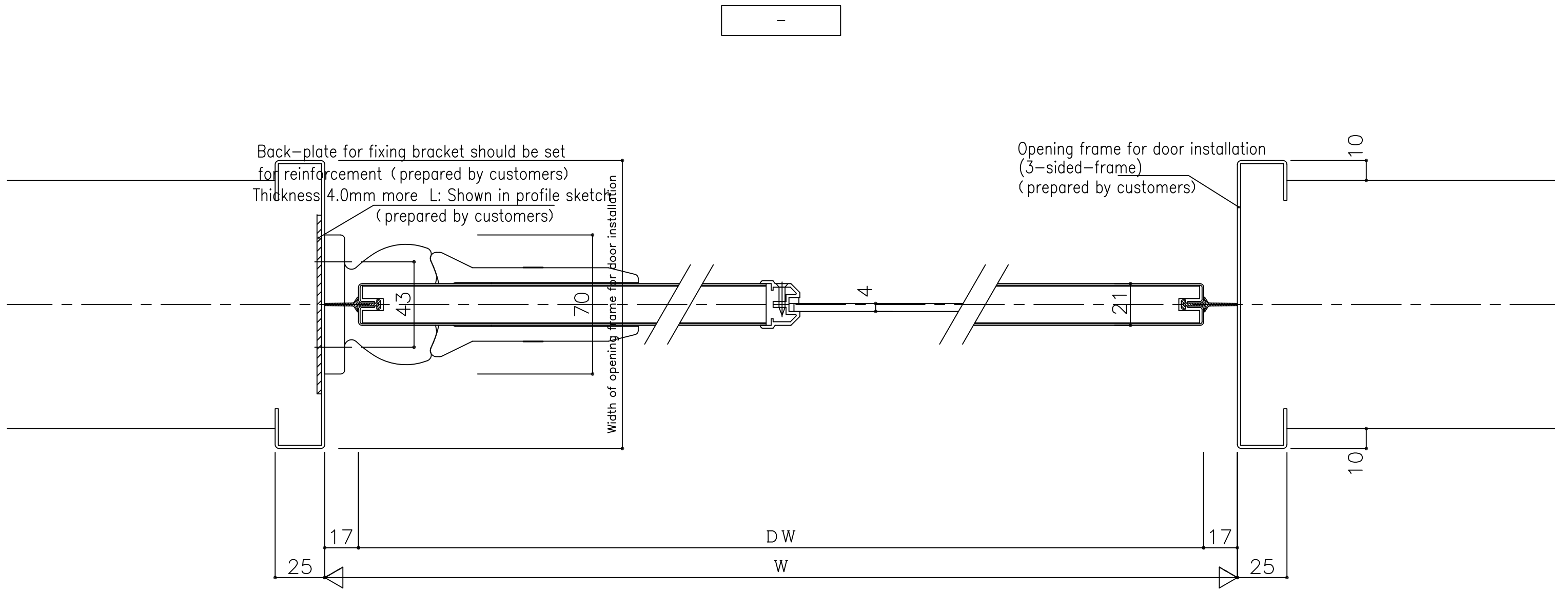

A-A' section

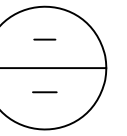

-	o	o	-
o	o		
o	o		
o	o		
o	o		

Drawing name
 UNIFLOW SWING DOOR
 SCG-3V (single door)
 cross section



Scale	1/2	-
Drawing No.	-	-
Date	-	-